



Electronic Service Manuals

This electronic document is provided as a service to our customers. We do not create the contents of the information contained in this document. Should you have detailed questions pertaining to the information contained in this document, you may contact Michco, or the manufacturer which provided the original information in this electronic deliverable. Michco's only part in this electronic deliverable was the electronic assembly process. By providing this manual on line we are not guaranteeing parts availability.

You may contact Michco through the following methods:

Phone (517) 484-9312 or (800) 331-3339

2011 N. High St. -- Lansing, Michigan -- 48906

Fax: (517) 484-9836

Email: CustServe@Michco.com

Web site: www.Michco.Com

Parts Web site: www.FloorMachineParts.Com

Order Parts on Line at:

www.FloorMachineParts.Com

Directly to Parts & Service:

By Email: **Shop@Michco.com**

By Fax: (517) 702-2041

By Voice: Use numbers above.

Serving the Cleaning Industry Since 1922

Notice: All copyrighted material remains property of original owners, all trademarks are property of respective owners. Manuals are subject to Manufacturer's reproduction limitations. Originals or reproductions were provided by manufacturers through a request. We make no warranty as to the correctness of information provided in this document and you assume all risk. By placing these manuals on line we are not declaring our corporation to be an manufacturer authorized dealer or provider, please check our web site for authorized manufacturers we represent.



E89000-00



GS15

15" Grout Automatic Scrubber



Operator's Manual Parts Schematic

1.0 NOTES FOR THE CLIENT

This manual provides information concerning use, maintenance and safety of Dirt Dragon machine designed and constructed to guarantee maximum performance, comfort and ease of use in a variety of circumstances.

We invite you to read it with attention in order to avoid mistakes and obtain the best results.

In addition, we suggest you refer to it if problems should arise.

Before delivery, your Dirt Dragon machine was tested both in the factory and by our dealer to guarantee perfect functioning. To maintain the machine in this condition and assure trouble-free use, it is necessary to perform **periodic maintenance** as described in the manual (See page 11).

2.0 MODIFICATIONS AND IMPROVEMENTS

We reserve the right to carry out, when necessary, modifications and improvements without granting these improvements to previously sold machines.

3.0 CONVENTIONS AND LEGEND

Indications such as **RIGHT** or **LEFT**, **CLOCKWISE** or **COUNTER-CLOCKWISE** used in this booklet relate to the forward movements of the machine.

NOTE The paragraphs preceded by this symbol concern instructions which, if not followed, can cause **damage to the machine**.



The paragraphs preceded by this symbol concern instructions which, if not followed, can cause **damage to people**.



The paragraphs preceded by this symbol concern instructions which must be read **very carefully**.

Use this manual to get acquainted with the characteristics of the machine and better understand how to make the best use of them.

4.0 SAFETY RULES

Most accidents at work happen because of failure to adhere to the most simple safety regulations. Accident prevention information will only be effective if the operator collaborates actively and carefully. In particular, take account of the following rules:

1. **Read** the instructions in this manual carefully before using the machine.
2. **Forbid the use** of the machine by people who are not authorized and instructed by qualified personnel.
3. **Pay attention** to other people, especially children, who are present while the machine is in use.
4. **Check** that the power supply **sockets** are properly grounded and protected by thermal magnetic and differential switches.
5. **Make sure** that the electrical features of the mains fulfill the power supply requirements of the machine (*voltage, frequency, power draw*), given on the machine name plate.
6. **Avoid** exposing the machine to **flammable** materials or fumes (fuels, solvents, etc.) which could cause explosions.
7. **Repairs** must be performed only by our qualified personnel.
8. **Pull** the plug of the power supply cord out of the socket during maintenance operations.
9. **Take care** that the **power supply cord** for connection to the mains is not crushed or torn during use.
10. **Do not use** the machine when its power supply cord is crushed or torn.

11. **After you have replaced a component**, make sure all electrical connections are fixed in order to ensure sufficient resistance to cable pulling.
12. **Do not leave** the machine unattended when it is plugged in.
13. **DO NOT ALLOW THE SOLUTION PUMP TO RUN DRY** for more than **5 minutes**.

5.0 MACHINE IDENTIFICATION DATA

6.0 SERIAL NUMBER AND EC MARK

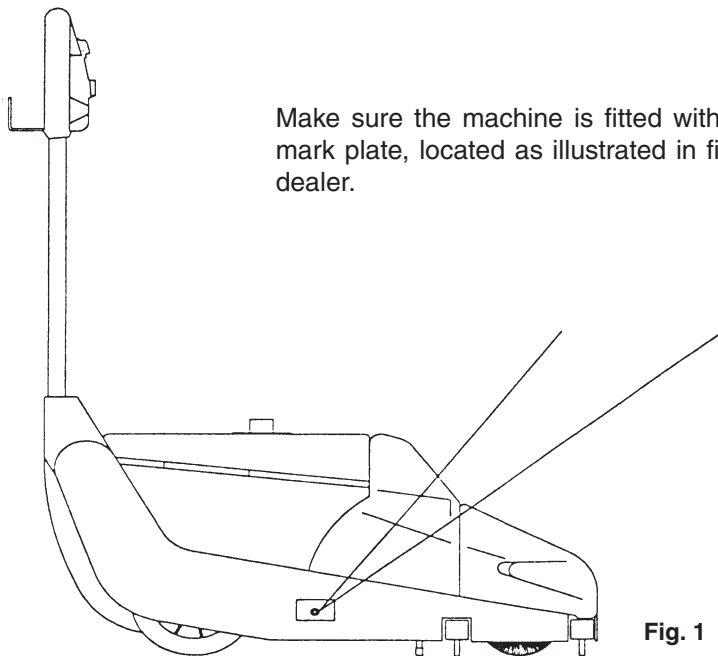

7.0 TECHNICAL SPECIFICATIONS

Cleaning width	14.8 in.
Floor wiper length	16.9 in.
Brush diameter	4 in.
Brush rotation	800 rpm
Brush pressure	17.5-35 lbs.
Brush motor power	370 watts
Suction motor power	100 watts
Suction vacuum	90.5 in. H ₂ O
Solution tank capacity	3.7 gal.
Waste water tank capacity	3.9 gal.
Accessory tank capacity	1.8 gal.
Wheels (diameter)	5.9 in.
Weight (with empty tanks)	79.4 lbs.
Overall dimensions w/o handlebar	30.5 x 17.5 x 14.6 in.
Equivalent level	78.5 dbA
Maximum level	80.7 dbA
Minimum level	76.5 dbA

The equivalent noise measurements refer to a machine operating in standard conditions of use. No operating **method** or **time** of use calls for the operator of the machine to take particular measures.

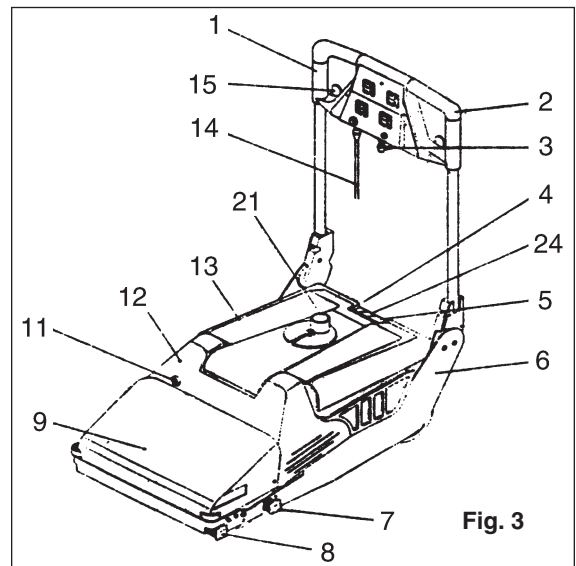
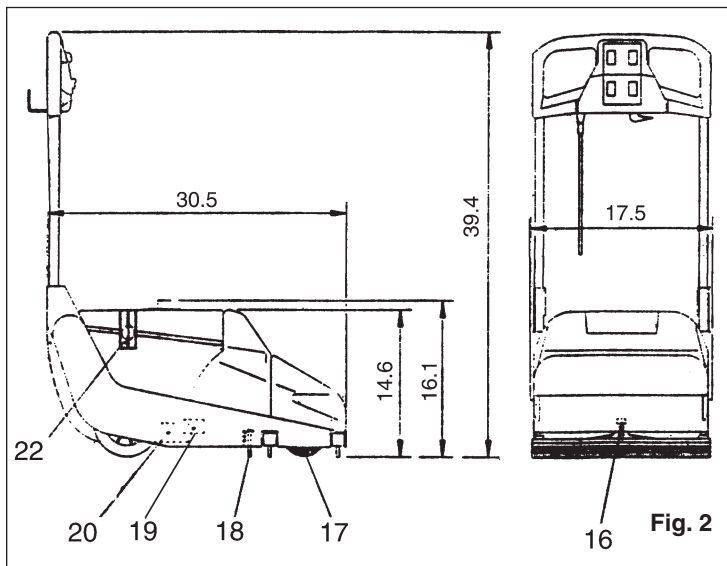

- | | | |
|---------------------|--------------------------|-------------------------|
| 1. Control panel | 9. Front bonnet | 18. Lifting device |
| 2. Hand grip | 11. Snap coupling * | 19. Serial number label |
| 3. Handle release | 12. Bonnet | 20. Filter |
| 4. Water tank | 13. Tanks cover | 21. Suction inlet * |
| 5. Waste water tank | 14. Power supply cord | 22. Float |
| 6. Chassis | 15. Cord hook | 24. Accessory tank |
| 7. Rear squeegee | 16. Pressure adj. device | |
| 8. Front squeegee | 17. Brush | |

* **Optional**

8.0 TRANSPORT

8.1 UNPACKING

Unpack the machine taking care to avoid any movements which could damage it. Check that all parts are integral. If this is not the case, DO NOT use the machine and consult your dealer.

8.2 CONTENTS OF THE PACKAGE

- 1 Machine
- 1 Use and maintenance booklet and Declaration of Conformity
- 1 Spare parts booklet
- 1 Guarantee coupon

If you notice any parts are missing, contact your dealer immediately.



Do not forget to place packing materials (bags, cardboard, pallet, ganci, and so on) **out of the reach of children.**

9.0 RANGE OF USES

MACHINE USE

Your machine is suitable for washing and drying floors and surfaces in general by exerting a vigorous brushing action and sucking up the washing water.

Any other use is *prohibited* as it may cause damage to things or persons.

The manufacturer cannot be held responsible for damage caused by the machine when used inappropriately.

NOTE



The machine must not be **tampered with**: in such cases the manufacturer **cannot be responsible** for any damage caused by use of the machine.



REMEMBER TO KEEP THE MACHINE **OUT OF THE REACH OF CHILDREN**

10.0 PREPARATION OF THE MACHINE

10.1 LIFTING

- Your machine should have the handle in **T** position (see FIG. 4).
- Grip both arms of the handle at the middle (**A**) (see FIG. 4).
- Lift the machine after checking that the articulation coupler is firmly fastened (try lifting the machine a few times).
- Push the handle to position **R** (FIG. 4).

10.2 TRANSFER

- The machine should have the handle in R position (see FIG.4)
- The power supply cord (14 FIG. 3) should be **disconnected from the mains** and wound onto the corresponding support (15 FIG. 3) of the handle.
- Lift the front part of the machine a little, using the handgrip of the handle, to push the machine forward.

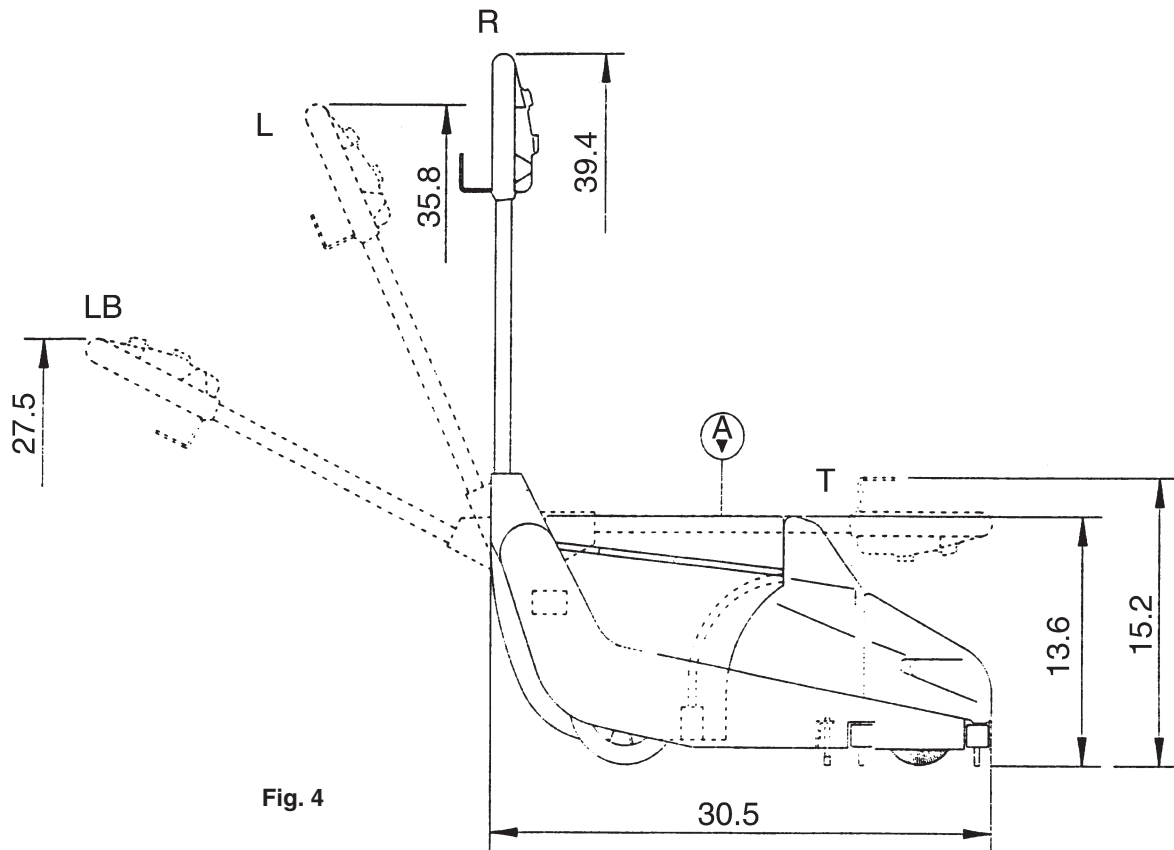

11.0 CONTROLS AND FUNCTIONAL PARTS

11.1 CONTROLS (FIG. 5)

- 1. Main switch**
Start/Stop switch for the current input.
- 2. Mains light**
Light that comes on when the plug is connected to the socket.
- 3. Handle release**
Operates the releasing of the handle articulation (give half a turn counter-clockwise).
- 4. Fuse**
Protects the electrical equipment.
- 5. Brush switch**
On/Off switch for operating the motor of the brush.
- 6. Suction switch**
On/Off switch for the suction motor.
- 7. Water pump switch**
On/Off switch for the pump.
- 8. Water pump button**
Button: as above (to operate the pump non-stop).

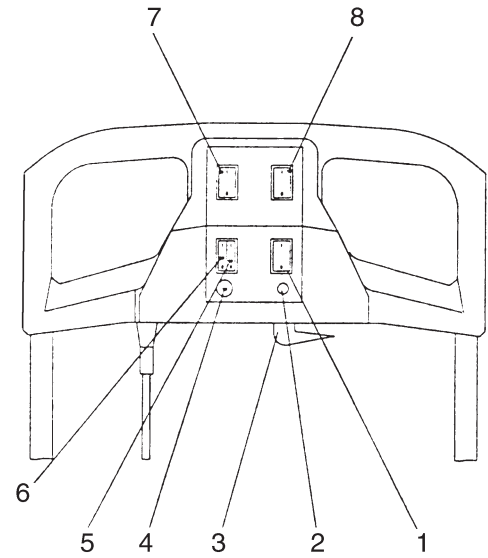

Fig. 5

11.2 HANDLE

The handle (2 FIG. 3) of your machine can assume four different positions.

To release, turn the lever (3 FIG. 3) counter-clockwise as far as it will go; this operation releases the two articulated joints simultaneously. The handle can adopt the following positions (FIG.4):

- T=Transport** In this position the machine is less bulky and can be lifted by gripping the handle in the midline (A).
- R=Rest** A special spring lifting device (18 FIG. 2) lifts the brush from the floor and therefore reduces the pressure exerted on the rubber pads of the squeegee, in order to avoid damage. In this position, the machine can be moved from room to room and stored.
- L=Work** In this position the lifting device is disconnected and the machine is ready for use.
- LB=Low work** To facilitate cleaning under tables, benches, furniture, etc., the handle can be released from its Work position and bent as far as desired.

NOTE The machine must be put away with the handle in T or R position after use.

11.3 FLOOR WIPER (SQUEEGEE)

Squeegees are devices that enable drying of the damp floor. If the machine is not drying effectively, check for any dirt or foreign matters on the squeegee. In this case, you will have to remove the squeegee to clean it.

11.3.1 DISASSEMBLY

- 1) Set the handle in R position (FIG. 4).
- 2) Remove the side lock of the squeegee support by pulling it upwards.
- 3) Remove the floor wiper by pulling it out as if it were a drawer from the opposite side of the locking.

ATTENTION: The lock on the rear squeegee is on the right of the machine, while that of the front squeegee is on the left.

11.3.2 ASSEMBLY

- 1) Put the floor wiper back by pushing it into its guides.
- 2) Insert the lateral lock in the special swallow tailed slide of the squeegee support and press it down.

N.B. refit the squeegees back in the same position.

11.4 BRUSH

The brush ensures removal of dirt thanks to its mechanical action on the floor.

If you are using the machine in particularly dirty environments, the self-cleaning system of the brushes may not be sufficient. In this event, we recommend you to remove the brush and wash it by hand.

11.4.1 DISASSEMBLY

- 1) Remove the front bonnet (1 FIG. 6) by grasping its side and pulling outward.
- 2) Turn the brush (3 FIG. 6) so that its coupling lever (2 FIG. 6), located on its right hand side, is facing upwards.
- 3) Push the roll coupling lever axially (2 FIG. 6) in such a way as to release it and, at the same time, press the roll down and pull it out crosswise.

11.4.2 ASSEMBLY (FIG. 7)

To refit the brush, carry out the above operations in reverse order.

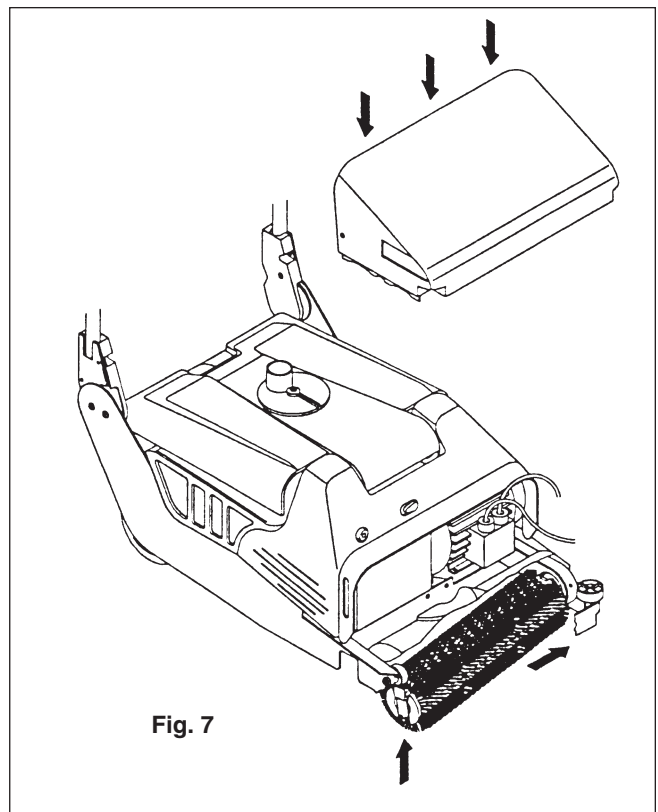
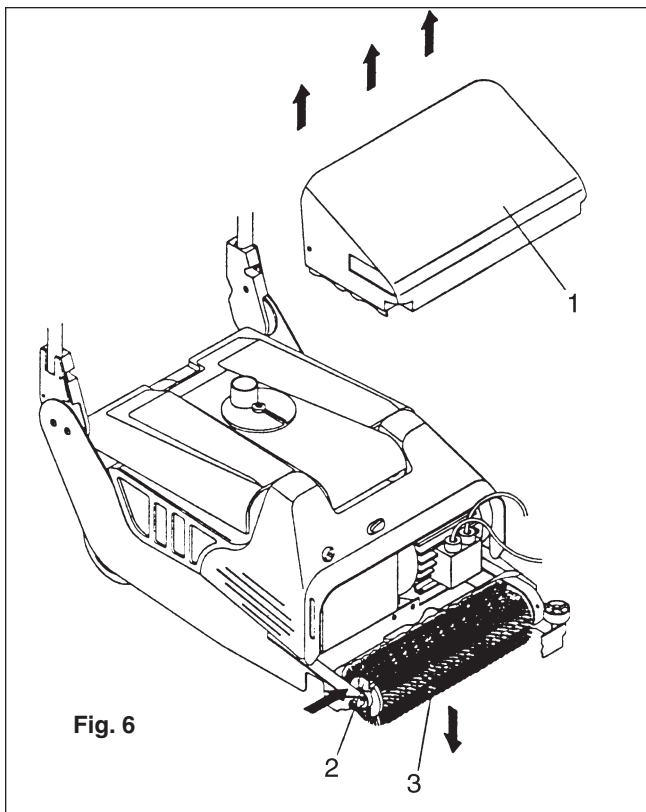

11.5 SQUEEGEE ADJUSTMENT

The floor wipers are fitted with pressure adjustment devices so as to suit different types of surface.

To regulate the pressure of the rubber lips turn the adjustment device (1 FIG. 8) clockwise to increase pressure or counter-clockwise to reduce it.

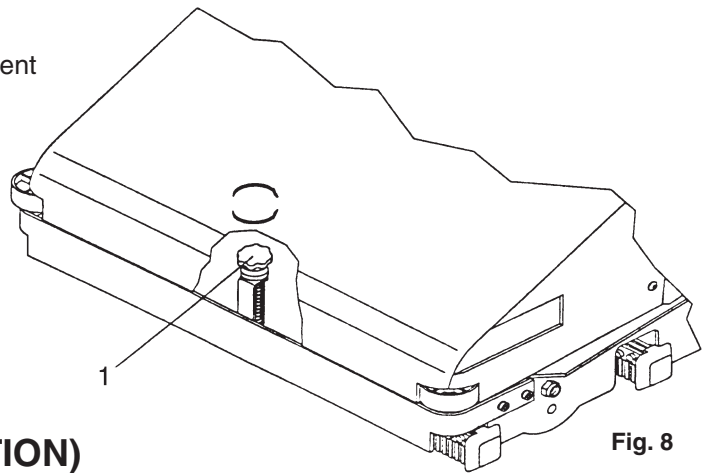

Fig. 8

11.6 FRESH WATER TANK (SOLUTION)

This contains the detergent solution (3.7 gal.) and is filled in the following way:

1. Lift the cover (13 FIG. 3) and tip it onto the front part of the machine.
2. Fill the fresh water tank (4 FIG. 3).

NOTE The maximum water level is 1.5 in. from the top of the tank.

3. Add detergent according to the instructions given by the detergent manufacturer.
4. Lower the cover.

11.7 WASTE WATER TANK

1. *Lift the cover* and tip it onto the front part of the machine.
2. *Pull out the waste water tank* by gripping it by the handles positioned at the sides of the opening and pulling it upwards.
3. *Pour the waste water* into a wash basin or drain and rinse it with fresh water.
4. *Put the tank* back on the machine and lower the cover. Make sure it is firmly shut before starting your work. Staff up the suction system and try lifting the cover: difficulty lifting the cover means that it is firmly shut.

11.8 ACCESSORY TANK

This contains the detergent solution (1.8 gal.) and is filled in the following way:

1. Lift the cover (13 FIG. 3) and tip it onto the front part of the machine.
2. Fill the fresh water tank (24 FIG. 3).

11.9 SUCTION SYSTEM FLOAT

NOTE When the level of dirty water in the tank has reached its maximum level, a safety system (float) stops the machine's suction system.

When the float is activated, you will notice that the noise of the suction motor changes immediately. This means you must take the necessary corrective measures.

Stop the machine immediately and empty the tank as described in the previous paragraph.

12.0 ACCESSORIES



THIS OPERATION MUST BE CARRIED OUT WITH THE MACHINE OFF.

1. Connect the accessory pipe (1) to the relevant fitting (2).
2. Turn the suction inlet (2) counter-clockwise to activate suction.
3. Fit the water pipe (3) with the snap coupling (4).
4. Shut off the valve (5).
5. Turn on the machine using controls 1-6-7 (see FIG. 5). The accessory will wash and dry. At the end of your work, turn off the machine. To disconnect the accessory, open up the valve (5), release any residual pressure and disconnect the pipe. Shut off the suction inlet before turning on the machine.

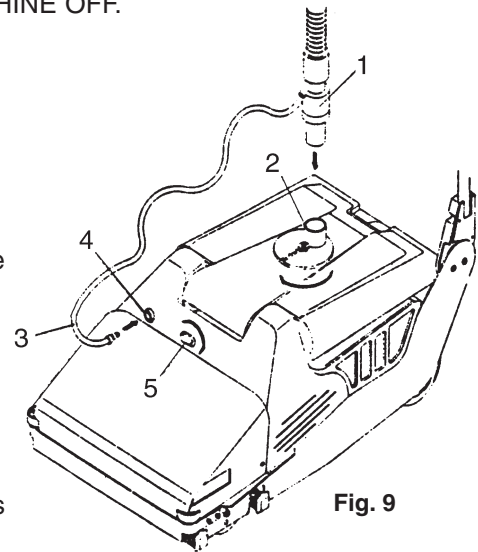

Fig. 9



IT IS STRICTLY PROHIBITED to touch moving parts of the machine and to remove the front bonnet while the machine is operating.

13.0 ELECTRICAL CONNECTIONS

The electrical features of the machine are printed on the serial number label (1 FIG. 1): check that the **frequency and voltage correspond** exactly to those of the electric system of the room where you are working.



Make sure the mains is effectively grounded and that the sockets and adapters used guarantee the continuity of the grounding wires.

NOTE



Failure to observe these instructions may cause severe damage or injuries, apart from forfeiting the guarantee.

14.0 PREPARING THE MACHINE FOR WORK

1. *Empty out the waste water tank.*
2. If necessary, *wipe the filter* (20 FIG. 2), which is located inside the solution tank (4 FIG. 3), clean.
3. *Fill the solution tank* with a suitable mixture of water and detergent.

NOTE

This operation must be carried out after checking that the *waste water tank has been completely emptied* to avoid damage to the suction motor.

15.0 STARTING UP

15.1 RULES FOR THE OPERATOR

- 1) **Do not pour** trichloroethylene, petrol, benzol, oil, acetone, hydrochloric acid, turpentine or other solvents into the tanks as these would damage the plastic or inflammable materials.
- 2) During use **make sure** that the power supply cord stays clear of the machine's operating radius and, in particular, that it does not get caught under the spinning roll.
- 3) **If black-outs occur**, turn the main switch to "0".
- 4) **Switch off** the machine after use, after having placed the handle in a vertical position.
- 5) **Use** the machine in dry and well lit rooms.
- 6) **Check** the condition of the electrical cables daily.
- 7) **Do not carry out** repair work on the machine when it is running and therefore plugged in.
- 8) **Check** that the work space around the operator is free from obstacles.
- 9) **The machine must only be used by adequately instructed personnel.**
- 10) **Store the machine** in a dry and sheltered place.

15.2 WORK

- 1) After preparing your machine, you can start washing and drying. It is recommended to move the machine along a pattern of orderly and slightly overlapping "strips".
- 2) Make sure all switches are in "stop" position (O) and plug in the machine.
- 3) Push the handle to work position (L).
- 4) Turn on the Main (1), Brush (5) and Water Pump (7) switches or (8) (Fig. 5).
Make sure the solution is evenly spread on the surfaces to wash by lifting the front part of the machine a little. This is done by pushing down the handgrip and pushing the machine forward.
- 5) For particularly dirty surfaces, it is advisable to switch off the suction motor and insist on the dirty surfaces by means of the combined action of the brush and the detergent.

NOTE Pay attention to the floor

- 6) Turn on the suction system (6).
Make sure drying is effective, otherwise you will have to *adjust the pressure of the squeegees*.
- 7) The active squeegee is always the forward one with respect to the movement of the machine (the retreated squeegee will be closed in this situation).

NOTE: To make the machine easier to use and to obtain the best results, we recommend you operate on straight strips of floor.

15.3 ENDING WORK

Empty out and rinse the waste water tank. Place the handle in rest (R) or transport (T) position (FIG. 4), ensuring that the brush and squeegees are not in contact with the floor.

16.0 PRACTICAL ADVICE FOR USE

- 1) With very dirty floors or floors which are particularly difficult to clean, the following washing and drying operations can be performed:

Pre-washing: switch on the main (1), brush (5) and water pump (7) switches, but not the suction motor one. Keep the machine within a particularly dirty area until it is clean.

Washing: spread a sufficient quantity of the cleaning solution onto the floor, switch off the water pump (7) and continue brushing, so that the solution can dissolve the dirt which will be thus removed by the brush.

Drying: switch on the suction motor (6) and pass over the previously washed strip.

- 2) **Simultaneous washing and drying:** switch on the brush (5), water pump (7) and suction motors simultaneously.
- 3) Do not keep the machine still when its brush is spinning.
- 4) Stop the supply of solution a few yards before changing direction.
- 5) To complete drying, switch on the brush and suction motors and switch off the water pump (7).
- 6) If the detergent solution stops flowing, *the detergent solution tank is likely to be empty.*
If you want to continue washing, the water pump (7) must be switched off, in order to prevent it running dry.
- 7) To guarantee effective operation of the machine, nonfoaming detergents must be used.

17.0 MAINTENANCE

17.1 GENERAL INFORMATION

Carry out periodic maintenance as described below:

Daily: Check that both tanks are perfectly clean before putting the machine away after use.
Make sure the solution tank filter is clean.

Weekly: Check that the lips of the rubber squeegees are in perfect condition. Make sure the openings of wiper blade supports are not clogged so that the solution can be completely removed from the floor.

Every six months: Have the electrical system checked by a qualified person.
Thoroughly wash the tanks and filter.
To do this, pour 2 quarts of a solution of 90% water, 10% decalcifying detergent into the fresh water tank and activate the pump until the tank has been completely emptied.
Rinse the tank with 1 quart of water, activating the pump until the tank is empty.



Do not carry out any of these procedures with the power supply cord plugged in.

17.2 CLEANING THE WATER FILTER

The filter can be removed without removing the rubber strip and washed carefully under running water.

NOTE Replace the filter with care.

17.3 CHANGING THE SQUEEGEE BLADES

If the squeegees are worn and their action is insufficient (even after they have been washed by hand), we recommend you replace them.

- 1) Remove the floor wiper (see par. 11.3.1).
- 2) Remove the drying blade and the counter-blade from the support.
- 3) Install the new blades making sure that the drying blade (without teeth) is placed on the open side of the support and that the counter-blade is on the opposite side.
- 4) Re-assemble the floor wiper (see par. 11.3.2).

ATTENTION: the stopping point of the support and the end of the aluminum squeegee support must match perfectly this does not happen, the support has been mounted back to front).

17.4 PROLONGED IDLE PERIODS

When the machine is at rest the **floor wiper** and the **brush must be raised** to avoid deformation of the drying blades and bristles.

To do this, place the handle in a vertical position and tip it forwards. The machine will be lifted by a specifically designed device.

During long periods of inactivity, wash out with a decalcifying solution as described in the instructions for “periodic maintenance.”

18.0 MARKING AND CERTIFICATION

The Dirt Dragon model has been examined in accordance to EEC directive 89/392 and subsequent modifications. The suitability is certified by the serial number label found on the machine, which bears the CE mark, and by the declaration of conformity which accompanies the following booklet.

19.0 DISPOSAL OF THE MACHINE

Being an assembly of various parts, we recommend you to dismantle the machine and separate the resulting materials in accordance to the laws in force.

DO NOT USE SCRAPS AS SPARES. KEEP THEM OUT OF THE REACH OF CHILDREN.

20.0 WIRING DIAGRAM

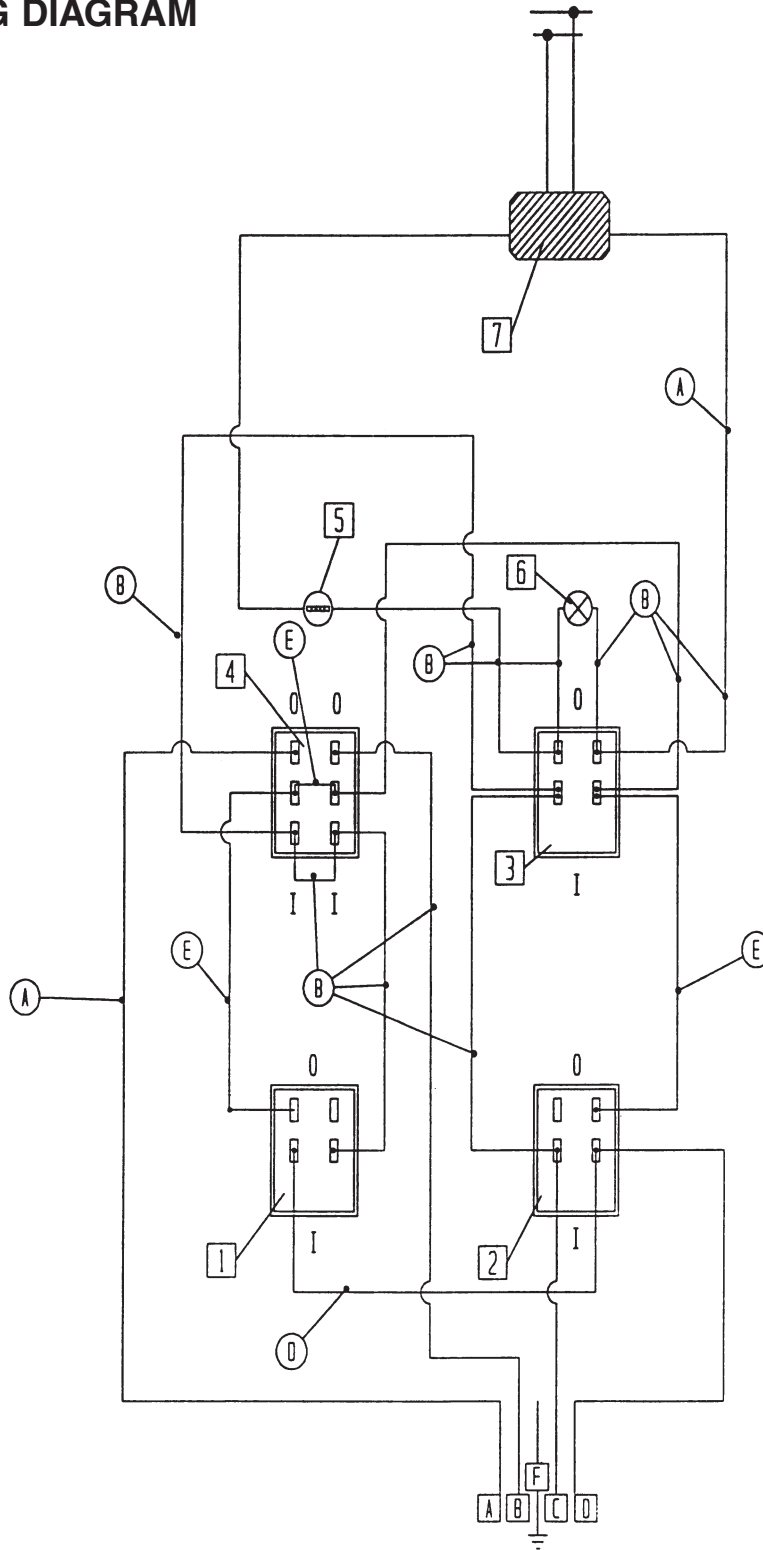

A: BROWN
 B: BLACK
 C: LIGHT BLUE
 D: BLUE
 E: RED
 F: GROUNDING

1: Water pump switch
 2: Water pump button
 3: Main switch
 4: Suction/brush switch
 5: Fuse 20A
 6: Main bulb
 7: Filter

21.0 TROUBLESHOOTING

Trouble	Cause	Remedy
The machine does not turn on	The ON/OFF switch is broken.....	Replace.
	The fuse has blown.....	Replace.
	The power cord is unplugged.....	Plug in.
The roll brush doesn't work	The main switch is off.....	Turn on main switch.
	There is an electrical or mechanical fault.....	Check the motor, condensator, and the drive belt.
The machine does not clean uniformly	The roll is worn.....	Replace.
The floor wiper does not suck up all the dirty liquid	The edge of the rubber blades in contact with the floor is blunt.....	Replace the worn blades.
	The pressure of the floor wiper is not correctly regulated.....	Regulate the floor wiper.
	There is obstruction or damage to the floor wiper or the connection.....	Remove obstructions and repair any damage, replacing rubber support.
The floor wiper does not suck up the dirt	The suction switch is off.....	Turn the suction switch on.
	The suction tubes are blocked.....	Free the tubes of blocked dirt.
	The suction motor does not work.....	Check the electronic connections of the suction motor and if correct replace.
Solution is not coming out	The pump switch is off.....	Turn the pump switch on.
	The solution tank is empty.....	Fill the tank.
	Blockage in the filter.....	Clean the filter.
	Blockage in the tubes carrying the solution.....	Clean the tube.
	The pump thermal switch has tripped.....	Allow the pump to cool, turning it off for 15 minutes.
	The pump is damaged.....	Repair or replace the pump.

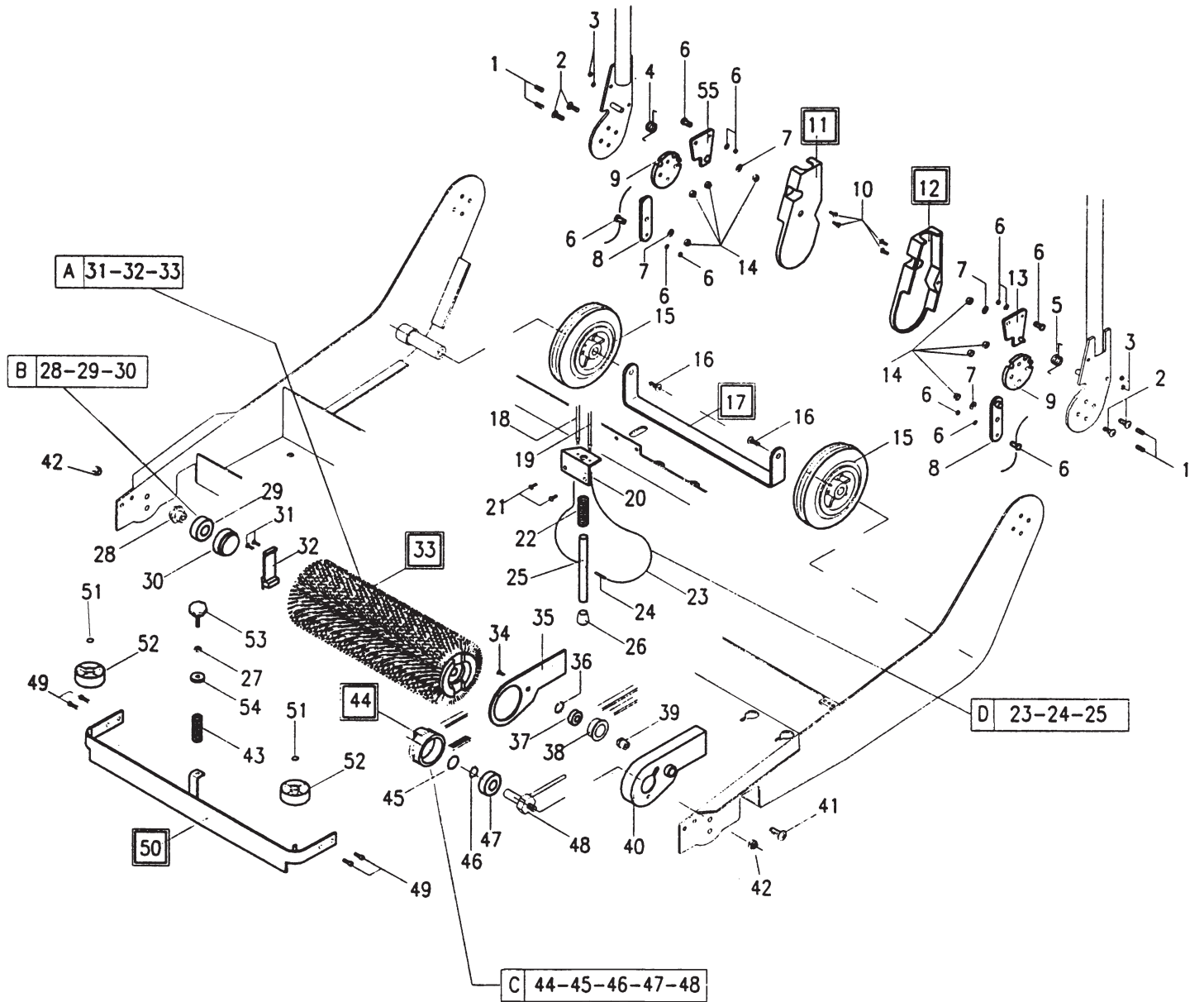

Ref.	Part No.	Description	Qty.
1.	1105606	Spring cotter, 4x16 din 1481	4
2.	1105182	Screw, iso 7380 6x22 zb	4
3.	1105121	Nut, uni 5588 M4	4
4.	22052006	Spring for right hand lever	1
5.	22052007	Spring for left hand	1
6.	1125027	Clamp micro	4
7.	1105786	Washer, uni 6592 6x18	4
8.	21902009	Lifting lever	2
9.	21302010	Gear wheel	2
10.	1105781	Screw uni 5933 4x12 zb	4
11.	21202009	Casing for the rh handle articulation	1
12.	21202010	Casing for the lh handle articulation	1
13.	21902005	Left hand articulation lever	1
14.	1105133	Locknut, M6 din 982	8
15.	22502031	Wheel Ø 150 - 40 - 70	2
16.	1105789	Screw, uni 5387 6x10	2
17.	22602016	Rear wheel axle support	1
18.	21252000	Lifting rod cable sheath, rh 1 865	1
19.	21252004	Sheath for the lifting rod cable, lh 1720	1
20.	22602011	Lifting bracket	1
21.	1105793	Self tapping screw, uni 6594 3.9x13	4
22.	22052011	Spring, Ø 16x72x2	1
23.	21252001	Cable for the lifting rod	1
24.	1105607	Spring cotter, 4x36 din 1481	1
25.	21002002	Machine lifting rod	1
26.	1320090	Cable cap, Ø 10	1
27.	1105123	Nut, uni 5588 M6	1
28.	22302012	Brush pin	1
29.	1390006	Bearing 6002 2RS	1
30.	21102017	Bushing for 6002 2RS bearing	1

Ref.	Part No.	Description	Qty.
31.	1105794	Self tapping screw + uni 6954 3.9x16	2
32.	21902001	Brush hooking lever	1
33.	23502008	Brush, dia. 100x375 Nylon	1
	23502005	Brush, dia. 100x375 Natural brush	
	23502007	Brush, dia. 100x375 Tynex	
	23502009	Brush, dia. 100x490 Nylon	
	23502008	Brush, dia. 100x490 Natural brush	
	23502010	Brush, dia. 100x490 Tynex	
34.	1105493	Screw, TCTC 4x10 INOX	1
35.	21202011	Belt guard lock,	1
36.	1105701	Inner snap ring, din 472 Ø 22	1
37.	1390005	Bearing 608 2RS	1
38.	22502002	Belt tightening roller	1
39.	22302013	Pin for the belt tightening roller	1
40.	21202012	Belt guard	1
41.	1105234	Screw, iso 7380 6x10	1
42.	1105134	Self-locking screw, din 985 M8	2
43.	22052010	Compression spring CO-41	1
44.	22502000	Driven pulley	1
45.	1160056	Corteco gasket 12-22-5	1
46.	1105422	Outer snap ring, din 471 Ø 20	1
47.	1390025	Bearing 6004 2RS	1
48.	22302020	Pulley pin with copper pipe	1
49.	1105784	Screw, iso 7380 5x12	4
50.	25002002	Bumper	1
51.	1105768	Outer snap ring, din 471 Ø 7	2
52.	22502030	Wheel, dia. 40 x 17x8	2
53.	1320089	Handwheel Ø 25 M16x25	1
54.	21102016	Bushing for the squeegee adj. spring	1
55.	21902004	Right hand articulation lever	1

Ref.	Part No.	Description
A.	23102000	Brush, Ø 100x375 Nylon
	23102051	Brush, Ø 100x375 Natural brush
	23102052	Brush, Ø 100x375 Tynex
	23102053	Brush, Ø 100x490 Nylon
	23102054	Brush, Ø 100x490 Natural brush
	23102055	Brush, Ø 100x490 Tynex
B.	23102021	Complete brush pin
C.	23102020	Complete driven pulley
D.	23102069	Complete machine lifting rod

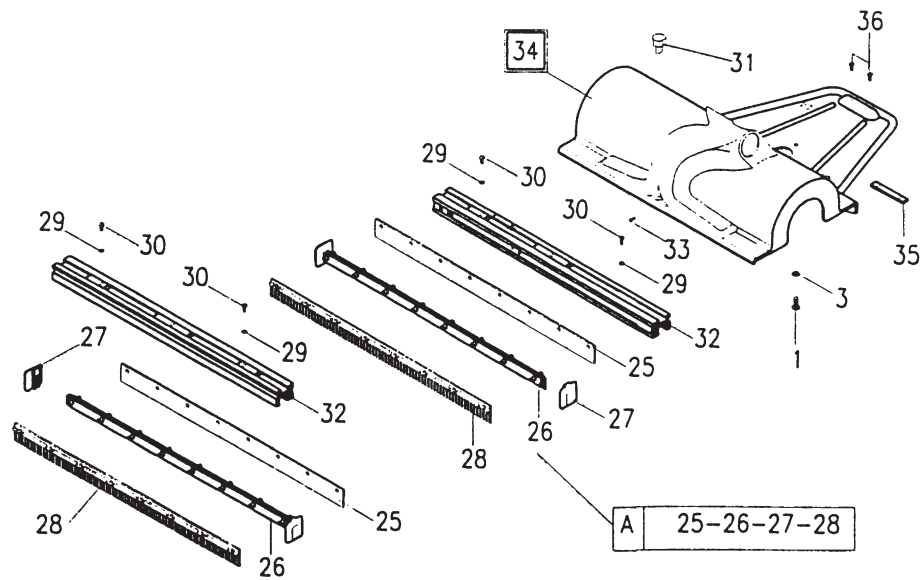
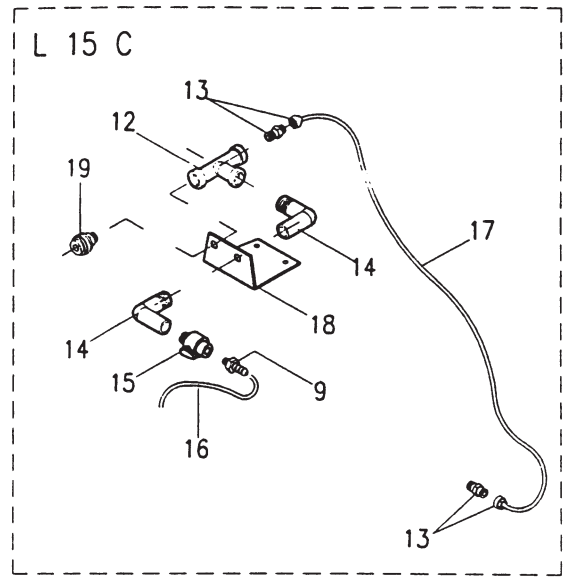
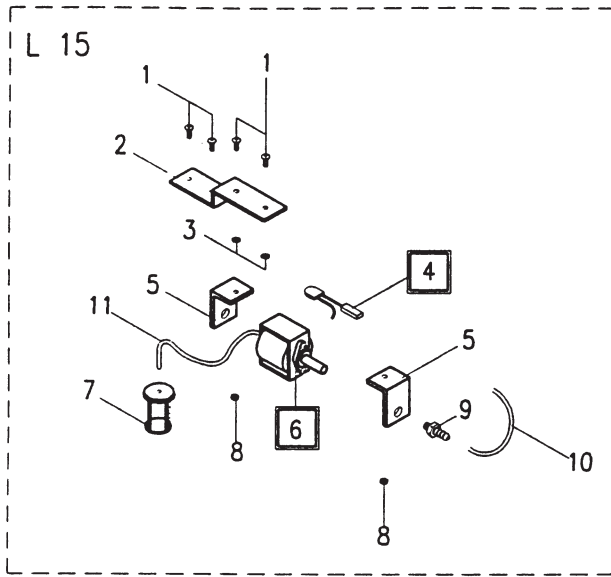

Ref.	Part No.	Description	Qty.
1.	1105494	Screw, 4x16 INOX	9
2.	22602010	Pump support bracket	1
3.	1108807	Washer, uni 6593 4x16	11
4.	13802018	Thermal protection for pump	1
5.	22602017	Pump vibration damping support	2
6.	14002001	Solution pump, 115V	1
7.	25002005	Filter for solution,	1
8.	1105121	Nut, uni 5588 M4	2
9.	1255003	1/8" hose fitting	1
10.	25002032	Supplementary pipe	1
11.	25002024	Pipe for solution	1
12.	1255010	1/8" FFF union tee	1
13.	1255009	Straight male pipe fitting, 8x6 1/8"	2
14.	1255007	1/8" MF union elbow	2
15.	1320088	Mini 1/8" ball valve	1
16.	25002009	Water pipe for brush	1
17.	25002010	Supplementary pipe	1
18.	22602012	Accessory support bracket	1
19.	1255025N	1/8" small coupling	1

Ref.	Part No.	Description	Qty.
20.	1255028	1/8" 6x8 union elbow	1
21.	1255034	1/4" 6x8 union elbow	1
22.	25002023	Supplementary pipe	1
23.	25002022	Water pipe for brush	1
25.	21602000	Wiper blade	2
26.	22602000	Blade support	2
27.	22602001	Squeegee cap	2
28.	21602001	Wiper blade	2
29.	1105330	Washer, uni 6593 4x12	9
30.	1105353	Self tapping screw + uni 6954 3.5 x 19	4
31.	21652001	Guide for the squeegee adjustment spring	1
32.	22602008	Squeegee pad support	2
33.	1105500	Screw, uni 5931 5x12	1
34.	21202040	Suction shute	1
35.	22602018	Fixing bracket	1
36.	1105784	Screw, iso 7380 5x12	2
A.	23102023	Complete KIT squeegee	

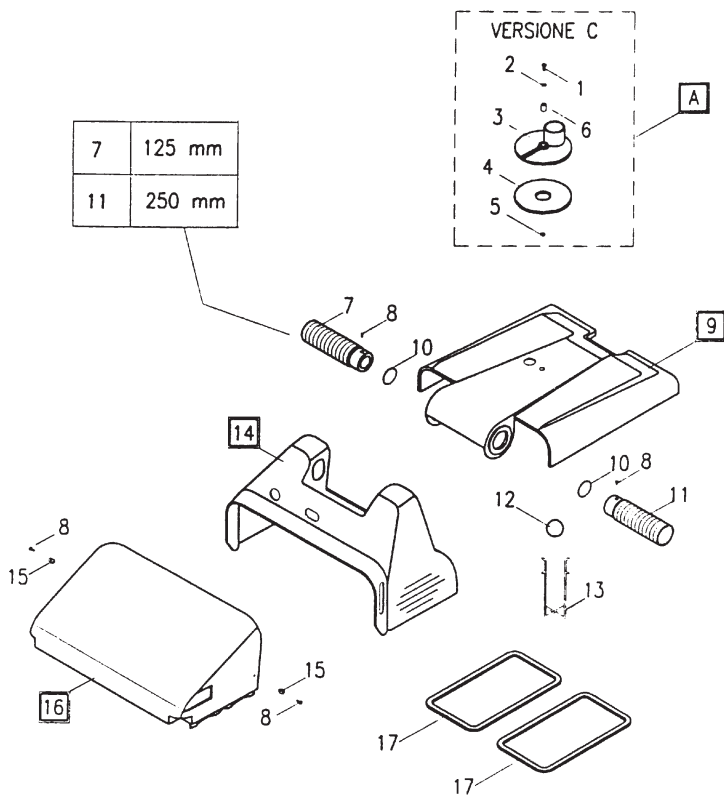

Ref.	Part No.	Description	Qty.
1.	1105802	Screw, TCTC 4x30 INOX	1
2.	1105330	Washer, uni 6593 4x12 INOX	1
3.	21202039	Suction accessory connection	1
4.	21602009	Gasket for accessory connection	1
5.	1105806	M4 split threaded rivet	1
6.	21102023	Bushing	1
7.	25002008	FLEX pipe, 120 mm	1
8.	1105793	Self tapping screw 3.9 x 13	4
9.	*	Cover	1
10.	1160048	3137 O-ring	2
11.	25002007	FLEX pipe, 250 mm	1
12.	25002004	Ball for float	1
13.	25002003	Cage for float	1
14.	*	Bonnet	1
15.	21602013	Rubber pad for bin	2
16.	*	Drawer	1
17.	23102001	Mousse kit for tank	1
18.	*	Recycling tank	1
19.	*	Solvent tank	1
20.	*	Accessory; tank	1
21.	*	Frame	1

* refer to Code Table, below

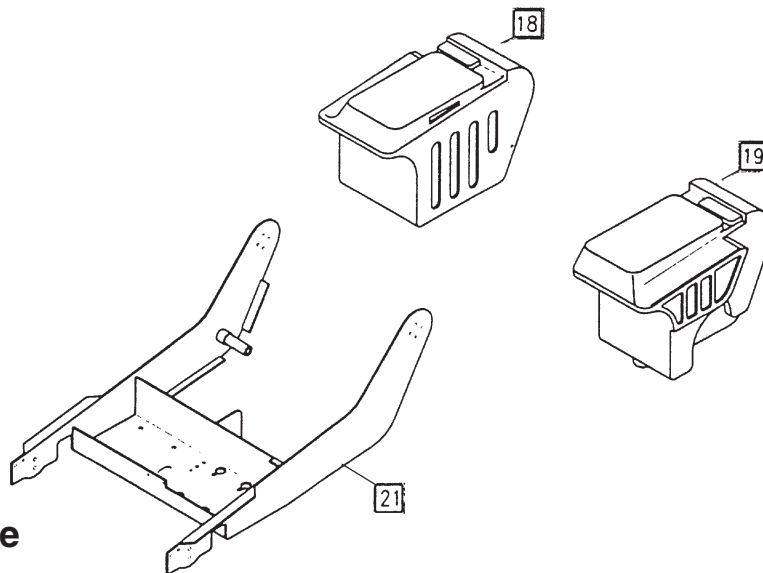

Code Table

Ref.	Description	PN: Red	PN: Blue	PN: Grey	PN: Lt. Blue
9.	Cover	21202058	21202062	21202060	21202059
	Cover complete	23102035	23102039	23102036	23102037
	Cover – L15C	21202071	21202068	21202072	21202067
	Cover complete – L15C	23102135	23102139	23102136	23102137
14.	Bonnet	21202045	21202049	21202048	21202046
	Bonnet – L15C	21202139	21202142	21202140	21202141
16.	Drawer	21202075	21202078	21202076	21202077
	Drawer complete	23102030	23102034	23102031	23102032
Ref.	Description	PN: White	PN: Black	PN: Grey	
18.	Recycling tank	21202050	21202054		
19.	Solvent tank	21202051	21202055		
20.	Accessory tank	21202090	21202092		
21.	Frame		22702006	22702007	

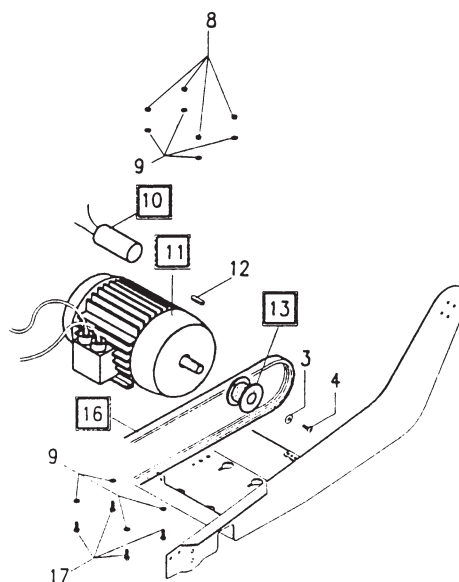
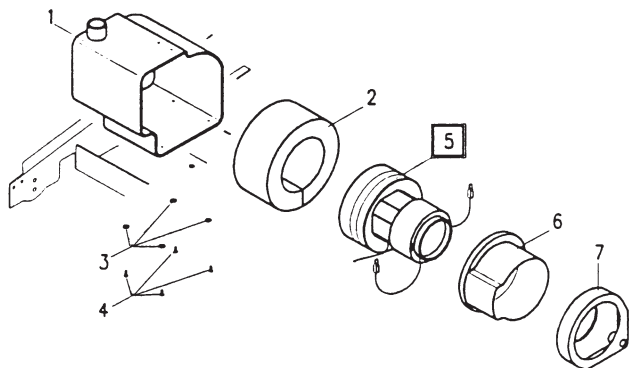

Ref.	Part No.	Description	Qty.
1.	23102005	Suction box	1
2.	21602010	MAPPYSIL deadening gasket	1
3.	1105807	Washer, uni 6592 4x16	5
4.	1105494	Screw, 4x16 INOX	4
5.	13402003	Vacuum motor	1
6.	21202088	Motor guard	1
7.	21202043	Motor cooling manifold	1
8.	1105123	Nut, uni 5588 M6	4
9.	1105324	Washer, uni 6593 6x18	8
10.	13802017	Capacitor 16pF	1
11.	13402002	Motor, 110 V	1
12.	1105465	Key, uni 6604 5x5x10	1
13.	22502021	Drive pulley	1
14.	1105064	Screw, TE 8x30	4
15.	1105326	Washer, uni 6593 8x24	8
16.	13302000	Poly belt, 558 4J	1
17.	1105779	Screw, uni 5739 6x25	4
18.	1105784	Screw, iso 7380 5x12	2
19.	21202138	Cooling air conveyor	1
22.	1105497	Screw, 5x16 INOX	4
23.	21202137	Suction compartment cover	1
24.	1105134	Lock nut, M8 din 982	4

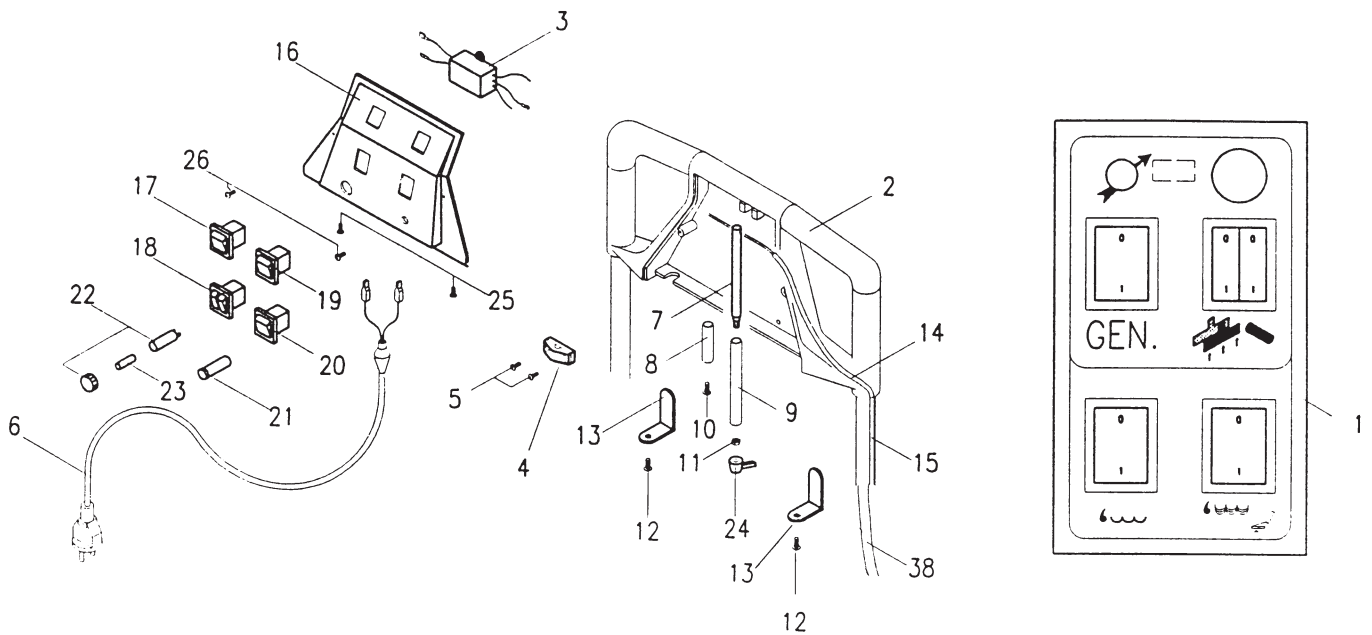

Ref.	Part No.	Description	Qty.
1.	169112008	Dashboard label	1
2.	222002005	Black handle	1
3.	13802015	Filter	1
4.	13802008	Core hitch, PA 238 RO	1
5.	1105805	Screw, 3.5 x 14.5	2
6.	21802005	Power supply cord with plug	1
7.	22302011	Handle release pin	1
8.	21102018	Handle release lever stop bushing	1
9.	21252005	Sheath for the release pin	1
10.	1105787	Self tapping screw, uni 6954 3.9x32	1
11.	1105123	Nut, uni5588 M6	2
12.	1105793	Self tapping screw, uni 6594 3.9x13	4
13.	22602015	Cable fixing bracket	2
14.	21252003	Handle release cable	1

Ref.	Part No.	Description	Qty.
15.	21252006	Sheath for the left handle cable	1
16.	21202100	Dashboard	1
17.	13802003	Bipolar switch with orange light	1
18.	13802005	Bipolar switch with double red-green light	1
19.	13802006	Bipolar switch with orange light	1
20.	13802004	Bipolar switch with green light	1
21.	21802013	Bulb cover with bulb	1
22.	13802014	Fuse carrier, 6x32	1
23.	13802025	Fuse, 20A 230V 6x32	1
24.	1190016	Handle release Lever	1
25.	1105792	Self tapping screw, uni 6954 3.9x9.5	2
26.	1105803	Screw M4x45	2